

Outline

- Introduction
- Transistors
- The CMOS inverter
- Technology
- Scaling
- Gates
- Sequential circuits
- Storage elements
- Phase-Locked Loops
- Example:
 - GOL

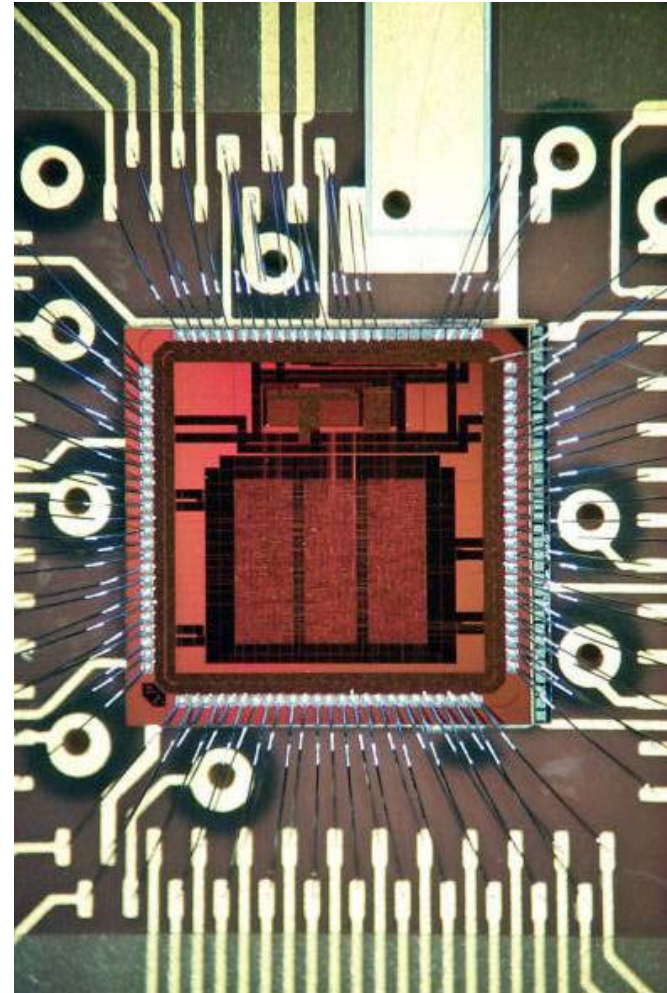

GOL - Rad tolerant Gbit/s serializer

- The GOL is a parallel-to-serial data transmitter:
 - At a rate of 40 MHz, it accepts 16 or 32-bit parallel data in
 - It generates a serial bit stream out at:
 - 0.8 Gbit/s for 16-bit in
 - 1.6 Gbit/s for 32-bit in
 - It is compatible with two standard line encoding protocols:
 - The G-Link
 - The 8B/10B
 - Two serial output drivers
 - 50 Ω differential
 - Laser/VCSEL

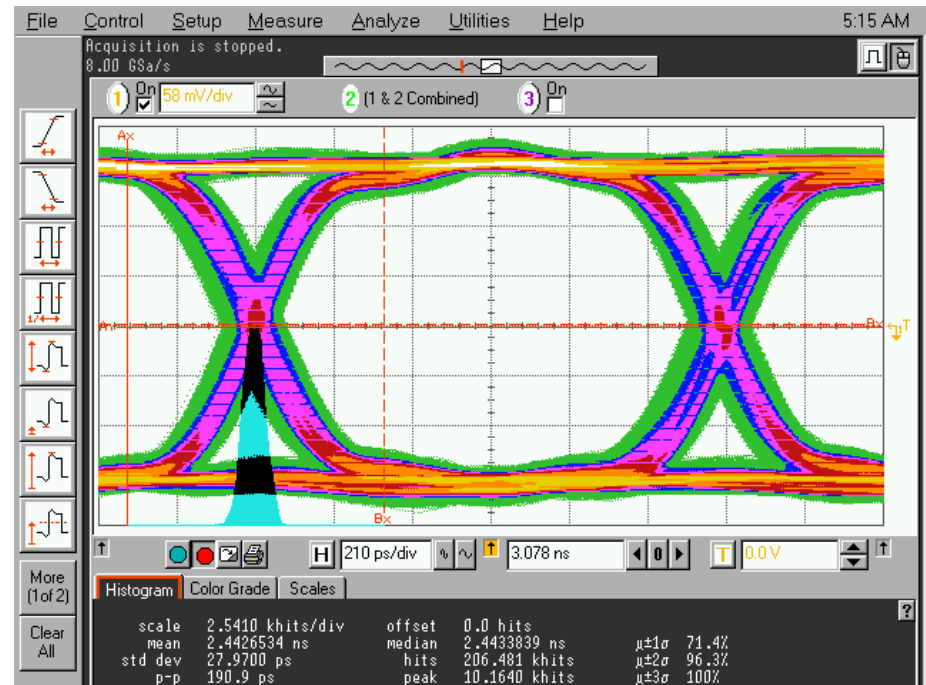

Data Serializers

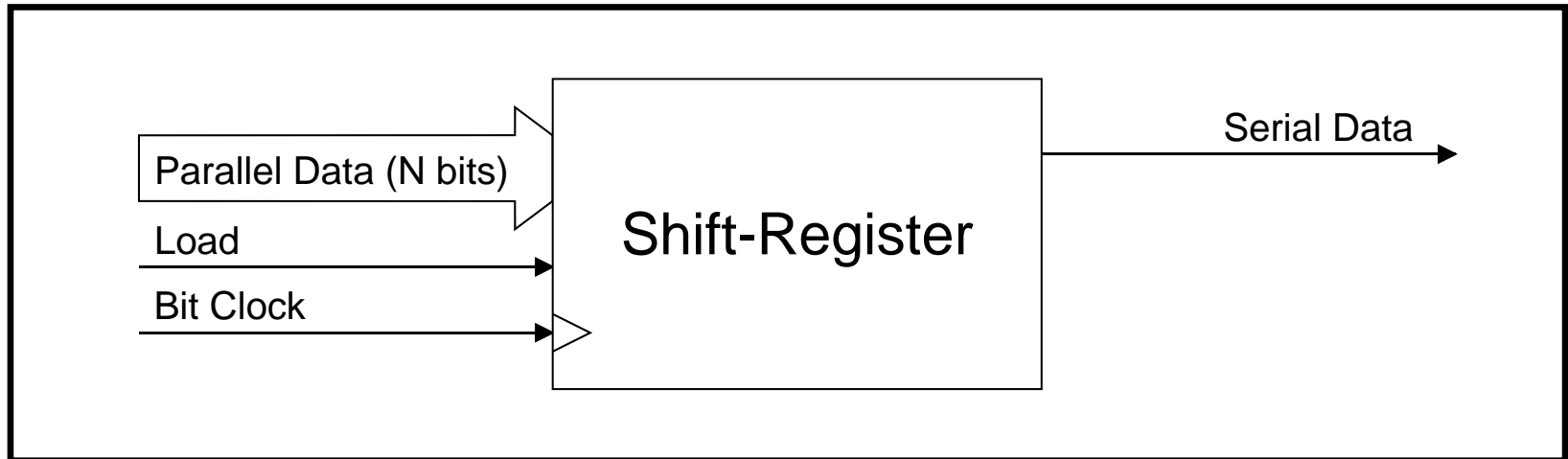

- What is a serializer?
 - A shift register!
 - Parallel loaded at the "word rate"
 - "Emptied" at the "bit rate"
 - "Bit rate" = (#bits in word) × (word rate)
- Would a simple shift register work?
 - NO!
 - There is no information about the bit boundaries (clock)
 - There is no information about the word boundaries (frame)

Data Serializers

- To be useful, a serializer must convert the raw data into a "line encoded" version.
- The line code "adds":
 - A number of "redundant" bits to the word being transmitted
 - Ensuring DC signal balance
 - Ensuring enough transitions for clock recovery
 - Identifying the frame/word boundaries
 - Providing a somehow limited error checking capability
- 8B/10B word encoding
 - Each 8-bit word is mapped into a 10-bit word
 - The maximum run length is 5 (enough transitions for clock recovery)
 - Maximum unbalance between 1s and 0s is ± 2
- CMIT word encoding
 - Adds 4 bits to each 16-bit word
 - Each frame has a well define master transition
 - The word to be transmitted is simply flipped or not depending on previous disparity and its own disparity

GOL: Architecture

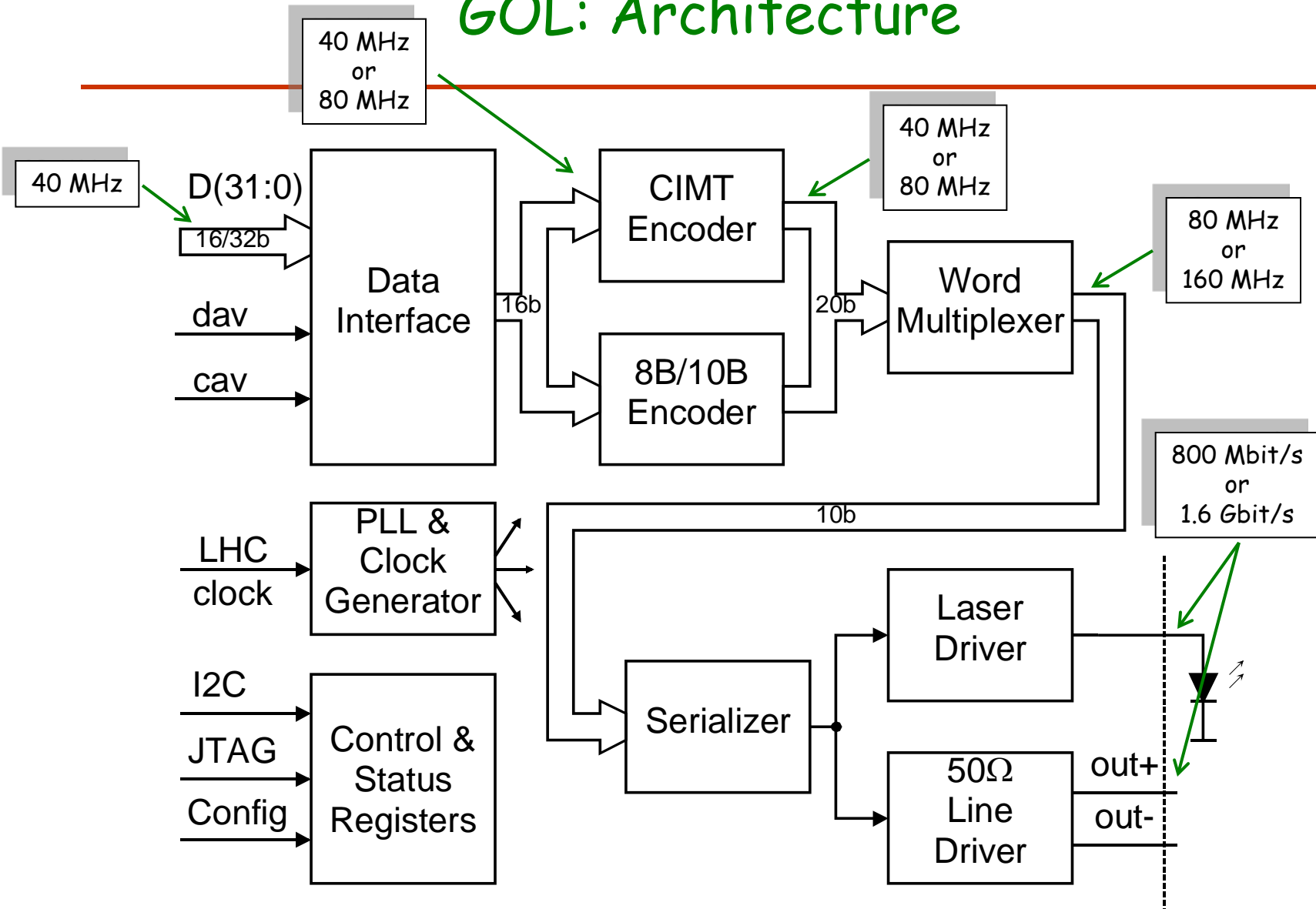

GOL: Serializer

- Parallel-load shift register:
 - cascade of flip-flops and 2-to-1 multiplexers
- Operation speed is limited by:
 - Clock to Q delay
 - Mux delay
 - Flip-flop setup time
- Maximum frequency:
 - $1/(t_{cq} + t_{mux} + t_{setup})$

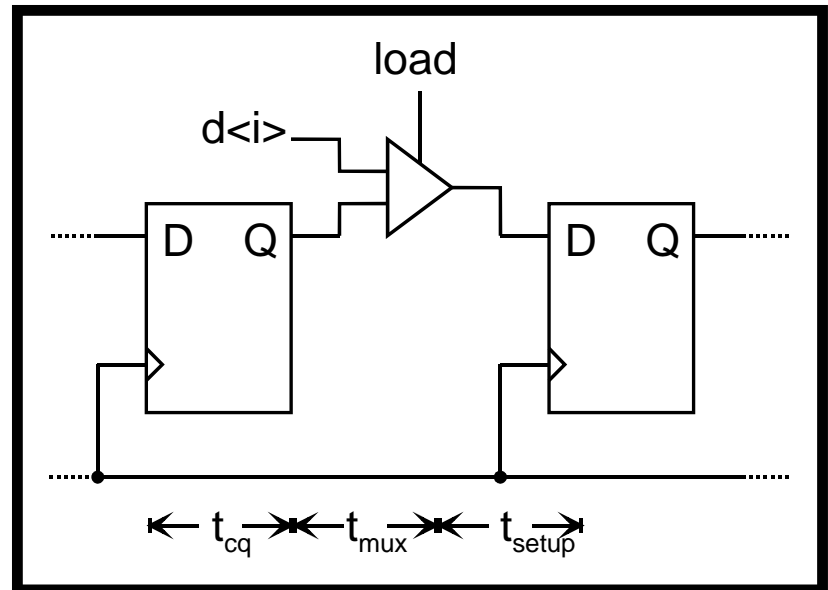

GOL: Serializer

- Maximum operation speed
 - 1.6 GHz \Rightarrow T = 625 ps
- Technology CMOS 0.25 μ m
 - Static FF t(min) = 1292ps ! (worst case)
 - Dynamic FF t(min) = 768ps (worst case)
 - For a safe design (good yield) any of the two FF is too slow

	DFF t_{pd} (ps)	DFF t_{sup} (ps)	SFF t_{pd} (ps)	SFF t_{sup} (ps)	MUX t_{pd} (ps)
typical	145	60	309	107	104
worst	369	152	749	296	247

GOL: Serializer

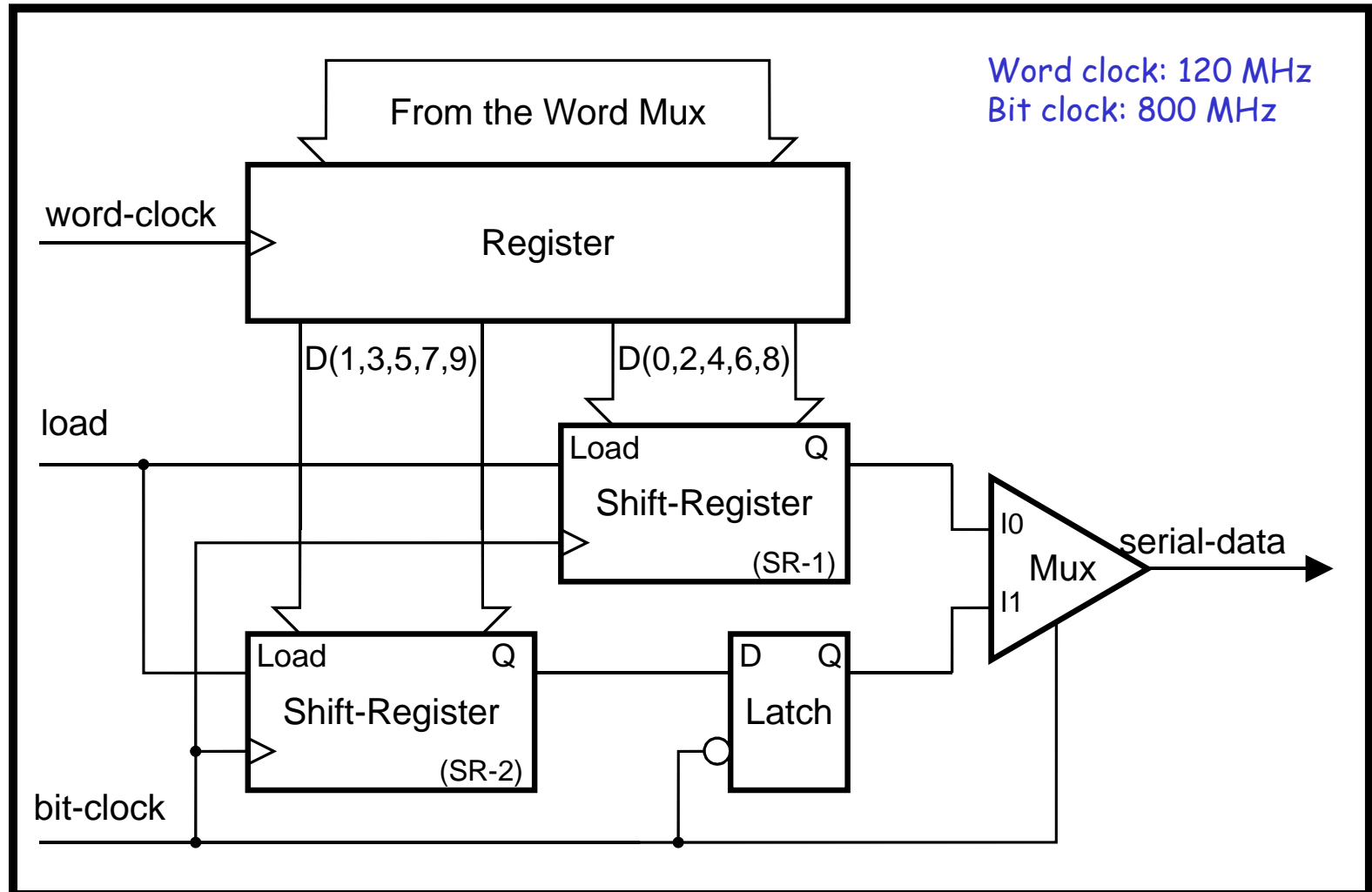

GOL: Serializer

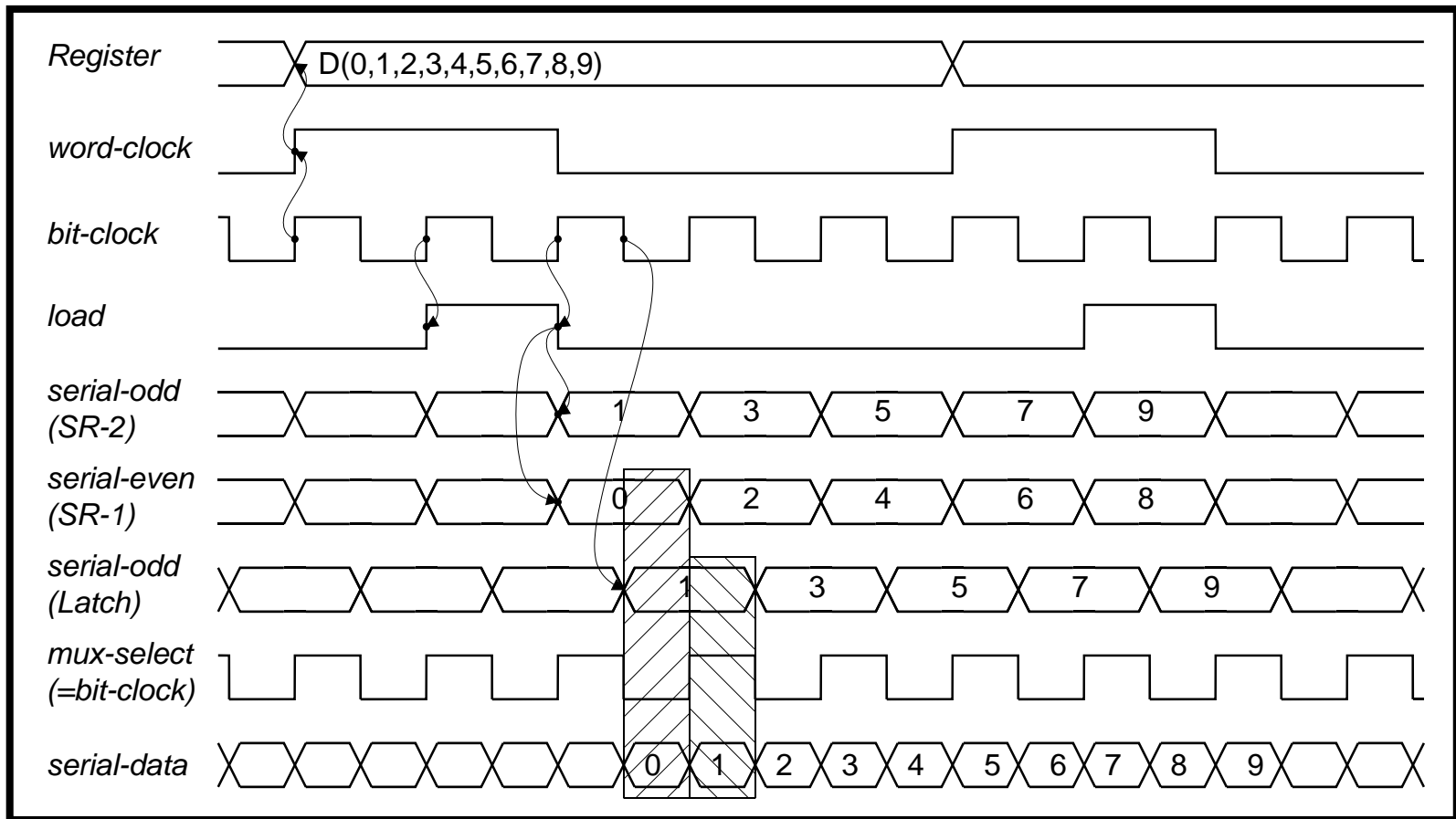

GOL Layout

